



# Reduce pressure and heat losses through intelligent utilisation of pumps

By Anders Nielsen, Application Manager, Grundfos

## 1. Introduction: how new pumps can help increase system efficiency

Traditionally we use pumps in hydronic systems to deliver the required flow and pressure – and that’s it, nothing more. Pumps with a built-in frequency drive have been around for years, but do we utilise their full potential? In this article, we will show that we do not.

### Purpose

One area where we see challenges in District Heating Systems is when we want to introduce Low Temperature District Heating. We will now look at some of these challenges and some of the possible solutions, using speed-controlled pumps.

### Contents

|  |           |
|--|-----------|
| <b>1. Introduction: how new pumps can help increase system efficiency.....</b>               | <b>1</b>  |
| <i>Purpose .....</i>   | <i>1</i>  |
| <b>2. The challenge of low temperature heating .....</b>                                     | <b>2</b>  |
| <i>The relation between flow and pressure.....</i>   | <i>3</i>  |
| <b>3. The solution to the challenge.....</b>   | <b>5</b>  |
| <i>Speed control an enabler for low temperature networks .....</i>                           | <i>5</i>  |
| <b>4. Other possibilities – a zone-divided solution to district heating efficiency .....</b> | <b>6</b>  |
| <i>Original temperature design .....</i>   | <i>7</i>  |
| <i>New temperature design .....</i>  | <i>8</i>  |
| <i>Combined approach.....</i>  | <i>9</i>  |
| <i>Installing mixing loops .....</i>   | <i>10</i> |
| <i>Summary .....</i>   | <i>11</i> |
| <b>5. Conclusion: .....</b>  | <b>11</b> |

## 2. The challenge of low temperature heating

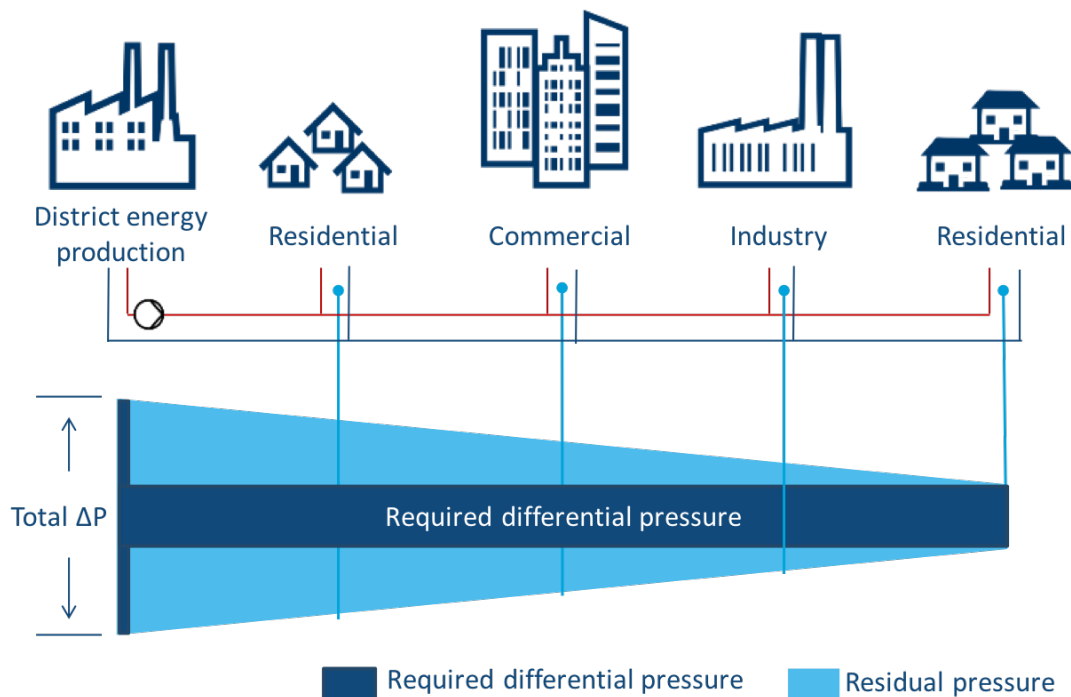

Fig 1: The traditional district heating system

In figure 1, we have a traditional system with a design flow temperature of 90° C and a return temperature of 55° C, giving a  $\Delta T$  of 35° C.

In this case, we set the District Heating plant to deliver a maximum capacity at 20 MW, which means the required flow is:  $20 * 860/35 = 491.4 \text{ m}^3/\text{h}$

Now if we want to operate the system using another temperature set such as 65° C/40° C, the consequence would be a  $\Delta T$  drop from 35° C to 25° C, as heat distribution is expressed by:

**$\Phi = Q * \Delta t$ , Power is equal to flow multiplied by  $\Delta T$ .**

This leads to the following new flow:  $20 * 860/25 = 688 \text{ m}^3/\text{h}$ , in other words we need a 40 % increase in flow demand to deliver the same heat capacity.

## The relation between flow and pressure

Based on affinity laws, we know that the relation between flow and pressure means that if we want to double the flow, the pressure resistance increases by a factor 4. In figure 2 below, the pressure increases from factor 1 to factor 4, even though the flow only doubles.

$$Q_1 \times (n_2/n_1) = Q_2$$

$$2 \times (1450/2900) = 1 \text{ m}^3/\text{h}$$
  

$$H_1 \times (n_2/n_1)^2 = H_2$$

$$4 \times (1450/2900)^2 = 1 \text{ m}$$
  

$$P_1 \times (n_2/n_1)^3 = P_2$$

$$1 \times (1450/2900)^3 = 0.125 \text{ kW}$$

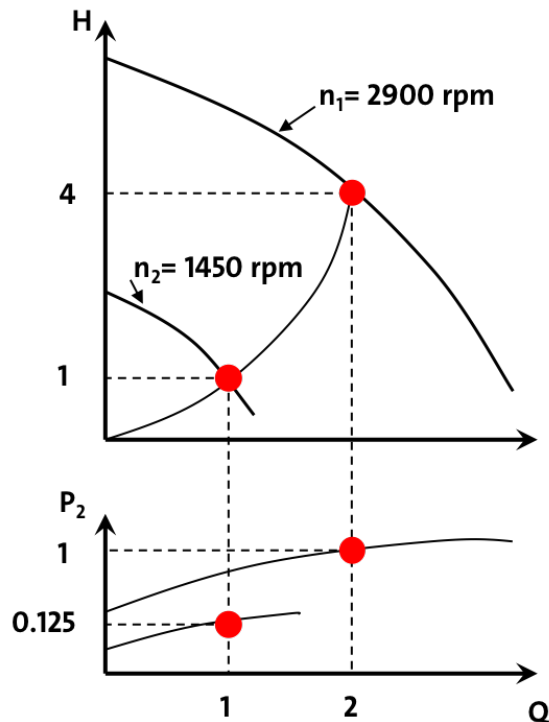

Fig 2: Consequences of increasing the pressure from factor 1 to factor 4, in line with the affinity laws

In this case, we increase the flow from 491 m<sup>3</sup>/h to 688 m<sup>3</sup>/h.

This leads to a  $(688/491)^2 = 1.96$  factor increase in pressure resistance. If we assume the distance from production to final residential consumer is 4000 m originally, we have a design pressure loss of 150 Pa/m, and this leads to a total *original* pressure loss of  $4000 \times 150 = 600,000 \text{ Pa} = 600 \text{ kPa}$ , equal to 6.0 bar. If we then increase the flow to the mentioned 688 m<sup>3</sup>/h, the pressure losses increase to  $1.96 \times 6.0 = \mathbf{11.8 \text{ bar}}$ .

In other words, the pressure per meter will be:  $150 \times 1.96 = 294 \text{ Pa/m}$ .

If we decide to add this required additional pressure at the same point as before, the resulting pressure profile will look as shown in figure 3.

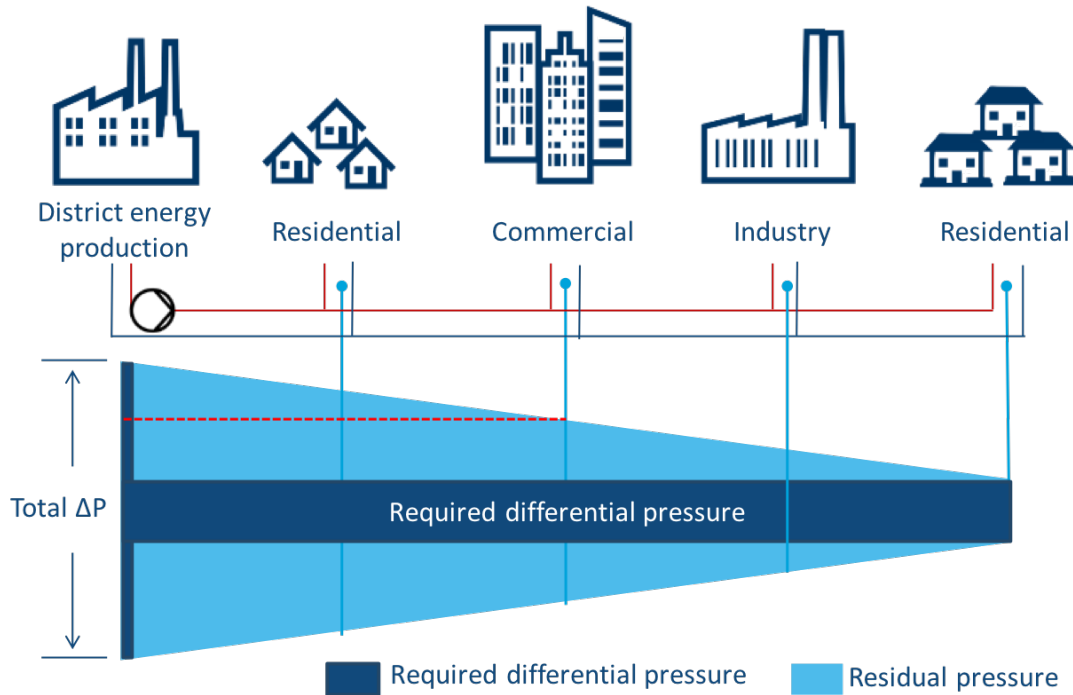

Fig 3: A lower forward pressure requires more flow (and pressure) to deliver the same the energy in the system:  $\Phi = Q * \Delta t$

It may be possible to add the pressure, however in this case the maximum pressure grade for the pipes is only 10 bar. The required pressure is 11.8 bar, and the maximum of 10 bar is clearly exceeded. Pressure above 10 bar is illustrated above the red dotted line.

### 3. The solution to the challenge

A solution to this challenge is shown in figure 4, where instead of adding all the pressure right at the beginning, it is possible to add the pressure when we need it.

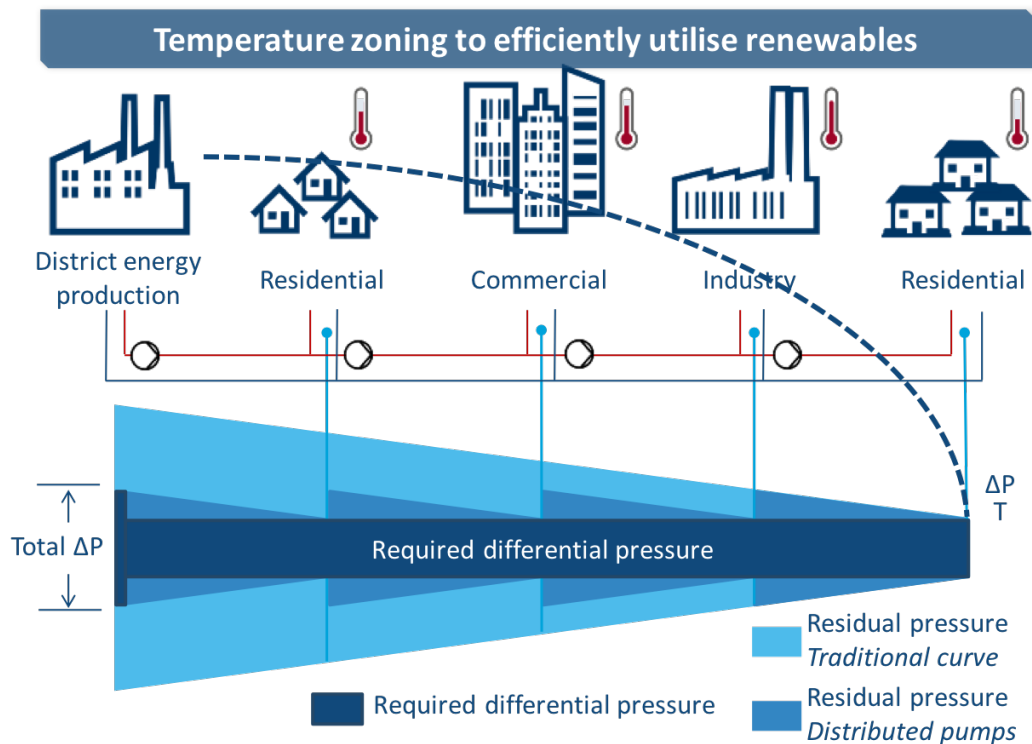

Fig 4: Solve the challenge of high pressure and loss by distributing pumps and adding pressure when needed:  $\Phi = Q * \Delta T$

The pumps connected in series will deliver only the required pressure until the next pump in line takes over. This moves the traditional approach with one spot for adding pressure to a dynamic adding of pressure. This is made possible when we utilise new modern pumps with speed – and therefore pressure – control.

#### Speed control an enabler for low temperature networks

This means that modern pumps can be an enabler for introducing Low Temperature District Heating. The positive side effect is that the differential pressure exposed in the system is generally reduced. With more manageable differential pressure at customer installations, the risk of by-pass is also reduced. It will be a challenge to prove that distributed pumps will lead to lower return water temperatures, but this might be possible too.

#### 4. Other possibilities – a zone-divided solution to district heating efficiency

A general reduction of flow temperature right from production might not always be the optimal solution for everyone. Some customers might need a higher temperature than modern new-build houses. In these cases, we could consider dynamic flow temperature adjustments in the network, where this is possible. An example of this solution is shown in figure 5.

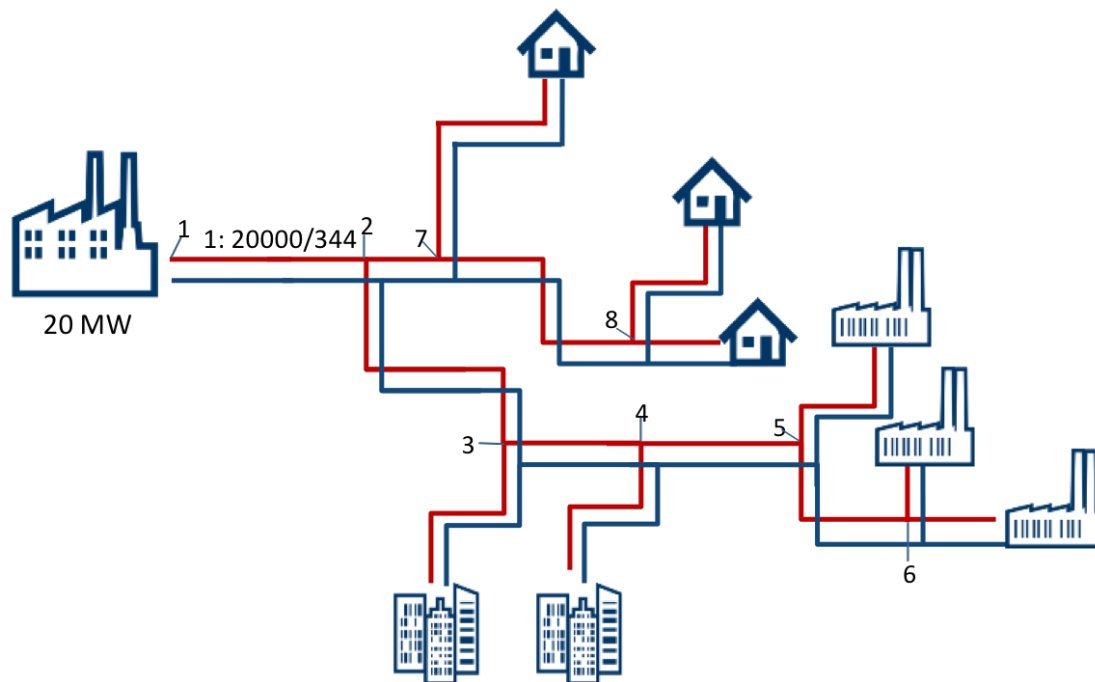

*Fig 5: Zone-divided district heating showing a tree structure with pipes “breaking off” the main pipes to deliver the required heat to connected buildings*

In a traditional tree-structured network, calculations have shown that flow temperatures can be reduced to 70° C. This is just an example, as each network has its own unique conditions for what is possible.

## Original temperature design

Firstly, figure 6 shows the heat losses as well as pump operating costs in the original design.

| SECTION                       | KW     | Q, M <sup>3</sup> /H | Q L/S     | METER | PIPE SIZE | PRES.LOSS/M | TOTAL PRES.LOSS/KPA |
|-------------------------------|--------|----------------------|-----------|-------|-----------|-------------|---------------------|
| 1 - 2                         | 20,000 | 344                  | 95.6      | 500   | 244.5     | 150         | 75                  |
| 2 - 3                         | 12,500 | 215                  | 59.7      | 450   | 219.1     | 120         | 54                  |
| 3 - 4                         | 10,000 | 172                  | 47.8      | 250   | 193.7     | 130         | 32.5                |
| 4 - 5                         | 7,500  | 129                  | 35.8      | 280   | 168.3     | 140         | 39.2                |
| 5 - 6                         | 5,000  | 86                   | 23.9      | 300   | M5RG      | 160         | 48                  |
|                               |        |                      |           |       |           |             | 248.7               |
| 2 - 7                         | 7,500  | 129                  | 35.8      | 100   | 168.3     | 140         | 14                  |
| 7 - 8                         | 5,000  | 86                   | 23.9      | 450   | M5RG      | 160         | 72                  |
|                               |        |                      |           |       |           |             | 86                  |
| NBG200-150-125/315            |        | Q: 344 H:24.9        |           |       |           |             |                     |
| Heat loss pipes/year kWh      |        |                      | 1,252,700 |       |           |             |                     |
| Operating cost pumps kWh/year |        |                      | 113,690   |       |           |             |                     |

Fig 6: Heat losses as well as pump operating costs in **the original design** with flow temperature 130° C and return temperature 80° C

With a  $\Delta T$  at 50° C, the flow rates are relatively modest, which also is reflected in the pump operating cost of 113,690 kWh/year. But with the high flow temperature, the heat losses are considerable, in this case 1,252,700 kWh/year.

## New temperature design

If we, in a new temperature design, lower the overall flow temperature to 70° C, the scenario will look as in figure 7.

| SECTION                       | KW     | Q, M <sup>3</sup> /H | Q L/S   | METER | PIPE SIZE | PRES.LOSS/M | TOTAL PRES.LOSS/KPA |
|-------------------------------|--------|----------------------|---------|-------|-----------|-------------|---------------------|
| 1 - 2                         | 20,000 | 688                  | 191.1   | 500   | 244.5     | 575         | 287.5               |
| 2 - 3                         | 12,500 | 430                  | 119.4   | 450   | 219.1     | 220         | 99                  |
| 3 - 4                         | 10,000 | 344                  | 95.6    | 250   | 193.7     | 500         | 125                 |
| 4 - 5                         | 7,500  | 258                  | 71.7    | 280   | 168.3     | 575         | 161                 |
| 5 - 6                         | 5,000  | 172                  | 47.8    | 300   | M5RG      | 740         | 222                 |
|                               |        |                      |         |       |           |             | 894.5               |
| 2 - 7                         | 7,500  | 258                  | 71.7    | 100   | 168.3     | 575         | 57.5                |
| 7 - 8                         | 5,000  | 172                  | 47.8    | 450   | M5RG      | 740         | 333                 |
|                               |        |                      |         |       |           |             | 390.5               |
| NK125-315/303                 |        | Q: 688 H: 89.5       |         |       |           |             |                     |
| Heat loss pipes/year kWh      |        |                      | 494,900 |       |           |             |                     |
| Operating cost pumps kWh/year |        |                      | 818,180 |       |           |             |                     |

Fig 7: Heat losses as well as pump operating costs with **a new temperature design** – flow temperature 70° C and return temperature 45° C

Now the heat losses will be reduced dramatically, but on the other hand the pump operating cost increases quite dramatically to 818,180 kWh/year for the original 113,690 kWh/year.



## Combined approach

The alternative to this could be a combined approach, as shown in figure 8, where flow temperatures are changed where possible.

| SECTION                       | KW     | Q, M <sup>3</sup> /H | Q L/S | METER | PIPE SIZE | PRES.LOSS/M | TOTAL PRES.LOSS/KPA |
|-------------------------------|--------|----------------------|-------|-------|-----------|-------------|---------------------|
| 1 - 2*                        | 20,000 | 382.2                | 106.2 | 500   | 244.5     | 160         | 80                  |
| 2 - 3                         | 12,500 | 430                  | 119.4 | 450   | 219.1     | 220         | 99                  |
| 3 - 4                         | 10,000 | 344                  | 95.6  | 250   | 193.7     | 500         | 125                 |
| 4 - 5                         | 7,500  | 258                  | 71.7  | 280   | 168.3     | 575         | 161                 |
| 5 - 6                         | 5,000  | 172                  | 47.8  | 300   | M5RG      | 740         | 222                 |
|                               |        |                      |       |       |           |             | 607                 |
| 2 - 7                         | 7,500  | 258                  | 71.7  | 100   | 168.3     | 575         | 57.5                |
| 7 - 8                         | 5,000  | 172                  | 47.8  | 450   | M5RG      | 740         | 333                 |
| Heat loss pipes/year kWh      |        | 549,300              |       |       |           |             |                     |
| Operating cost pumps kWh/year |        | 508,358              |       |       |           |             |                     |

\*Temperature: Flow 90° C and return 45° C – in the rest of the system: Flow 70° C and return 45° C

*Fig 8: Heat losses as well as pump operating costs with a combined approach – flow temperature 70/90° C and return temperature 45° C*

In a combined system, we run with a flow temperature of 90° C up to the first branching of the tree, shown as sections 1 and 2 in the tree-structured network.

## Installing mixing loops

Figure 9 repeats the tree structure shown in figure 5, now adding two arrows, where we now install two mixing loops in pits, enabling us to reduce the flow temperature from 90° C to 70° C.

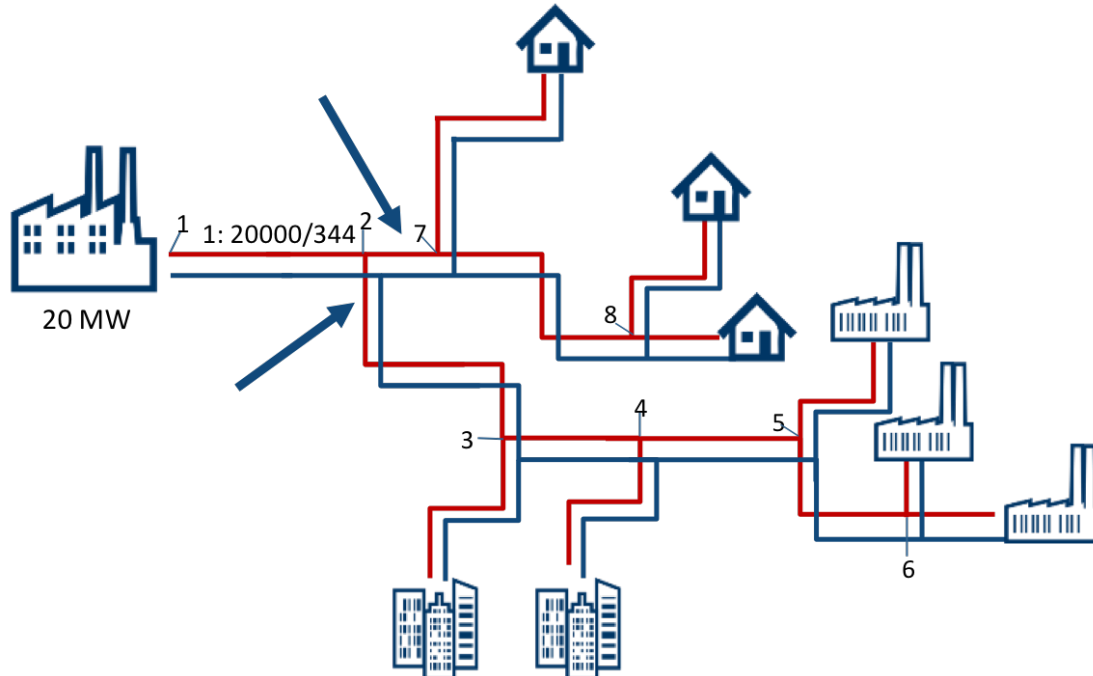

*Fig 9: Installing two mixing loops to reduce the flow temperature from 90° C to 70° C*

The positive effect is that the pressure loss in this part of the network is reduced from 287.5 to 80 kPa. This is the main reason why the total cost for operating the pumps is reduced to 508,358 kWh/year. This is however still an increase, but what is more important is that the associated heat losses are reduced from 1,252,700 kWh/year to 549,300 kWh/year.

This is a stunning 703,400 kWh/saving every year. On top of that, total CO<sub>2</sub> emissions will be reduced further, as the boilers will not have to produce this heat.

## Summary

In figure 10 below, we summarise the examples above and show the advantages of the intelligent combined approach.

|                                 | ORIGINAL DESIGN      | NEW TEMPERATURE DESIGN | COMBINED APPROACH    |
|---------------------------------|----------------------|------------------------|----------------------|
| Temperatures (flow/return)      | 130° C - 80° C       | 70° C - 45° C          | 90/70° C - 45° C     |
| Heat loss pipes/year kWh        | 1,252,700 kWh        | 494,900 kWh            | 549,300 kWh          |
| Operating cost pumps kWh/year   | 113,690 kWh          | 818,180 kWh            | 508,358 kWh          |
| <b>Total energy consumption</b> | <b>1,366,390 kWh</b> | <b>1,313,080 kWh</b>   | <b>1,057,658 kWh</b> |

*Fig 10: A summary of the comparison of zone-divided solutions to district heating efficiency, showing the advantages of the intelligent combined approach*

## 5. Conclusion

In this article, we have introduced the concepts of dynamic district heating, adding speed-controlled pumps when we need to boost pressure. As these pumps typically will be connected to an overall monitoring system such as SCADA, we can get information like temperature, flow and delivered heat energy\*. We can use this knowledge to increase system efficiency.

Where system design requires a 'in network' approach, we can adjust network temperature to the lowest possible levels. This dynamic approach is possible due to the use of pits with prefabricated mixing loops, including pumps and all required components.

\*This information is readily available in at least some new pumps.